

Uponor

Uponor Vario S manifold LS

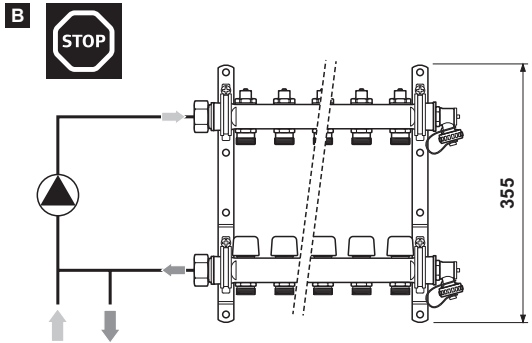
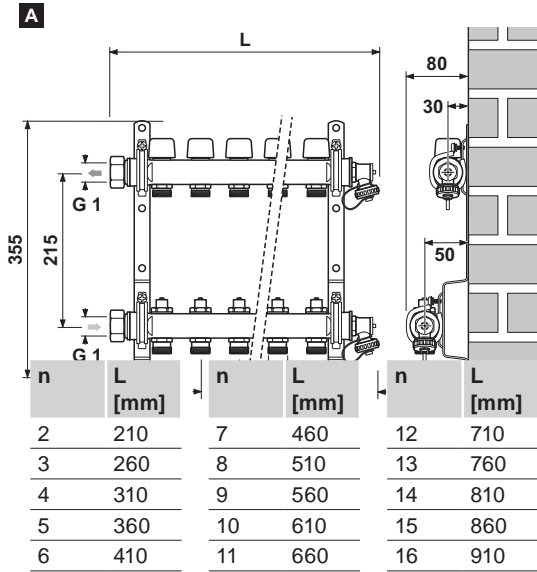
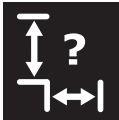
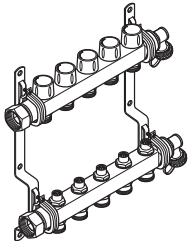

$\vartheta_{\text{sec}} = 15 - 60^{\circ}\text{C}$
 $P_{\text{max}} = 10 \text{ bar}$
 $P_{\text{test}} = 13 \text{ bar}$

$kvs = 3,82 \text{ m}^3/\text{h}$
 $kvs = 3,1 \text{ m}^3/\text{h}$
 $\dot{V}_{\text{max}} = 5 \text{ m}^3/\text{h} (12 \text{ loops})$

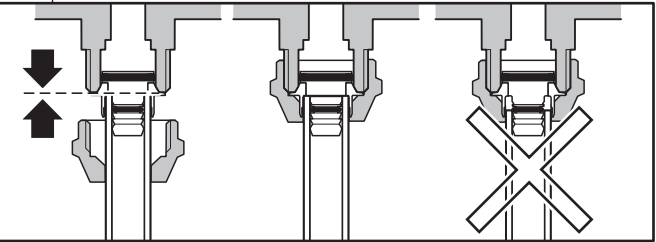
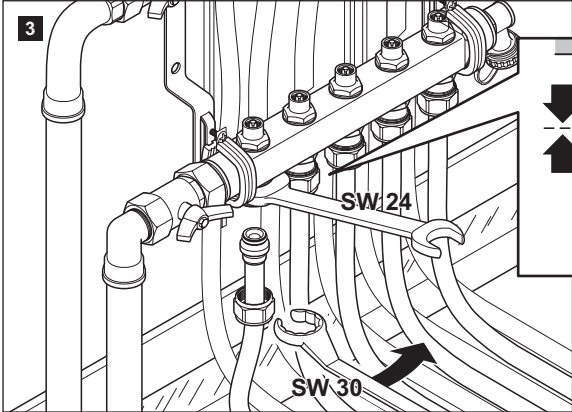
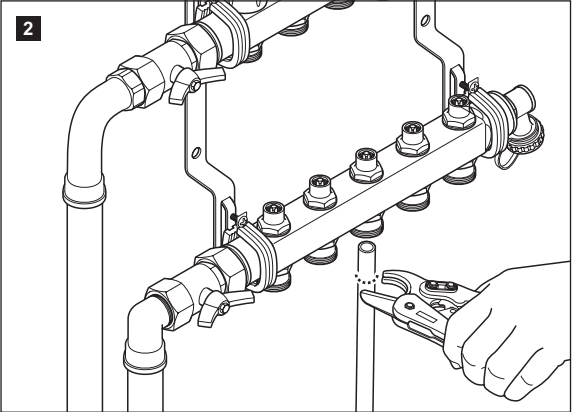
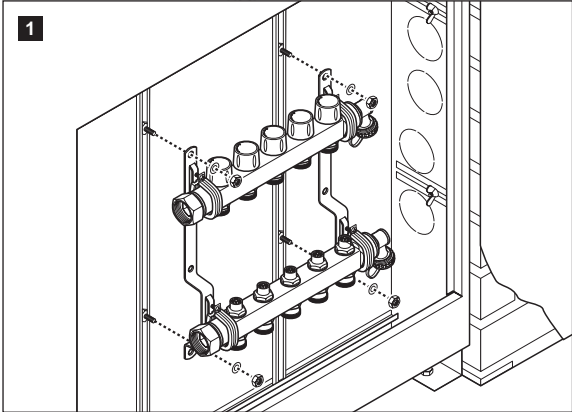

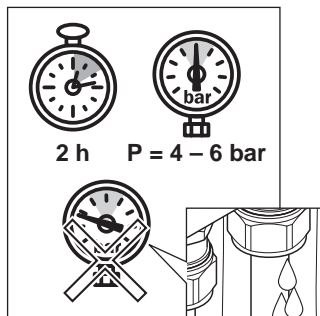
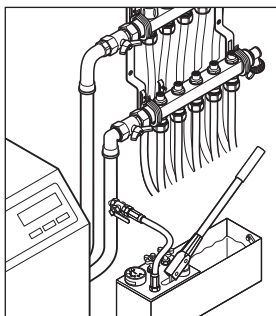
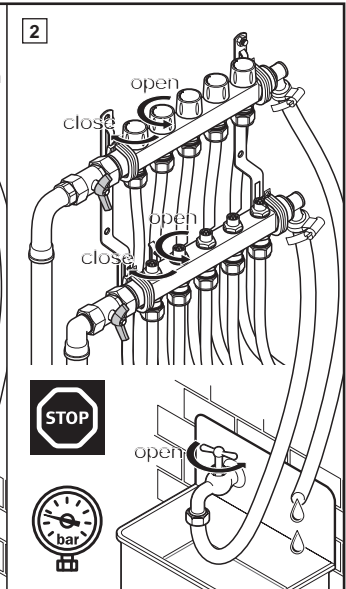
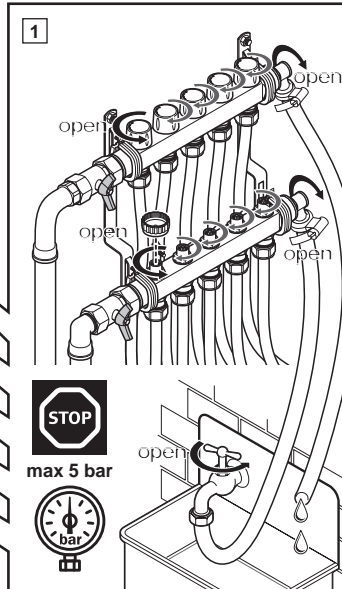
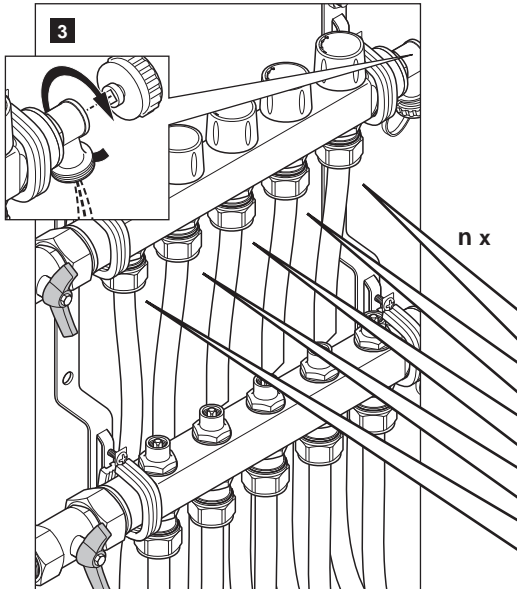
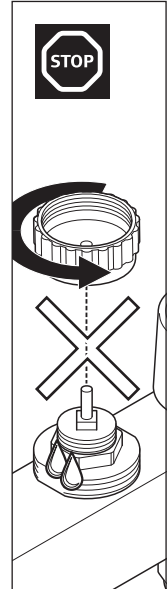
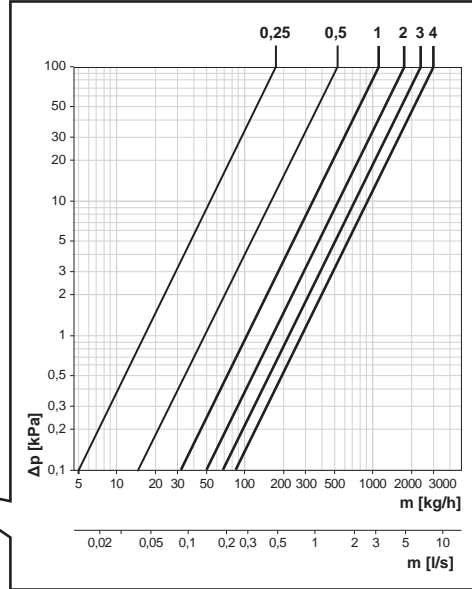
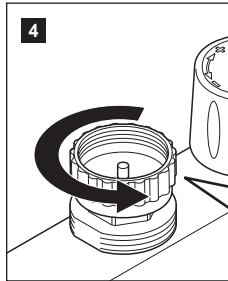
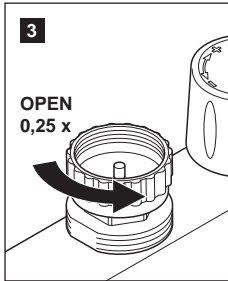
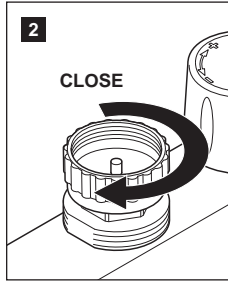
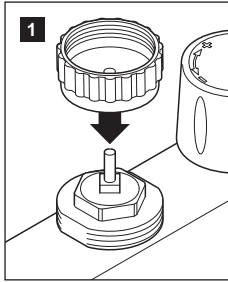

Uponor GmbH

Industriestraße 56,
D-97437 Hassfurt, Germany

1087992 03_2021_INT
Production: Uponor / ELO

Uponor reserves the right to make changes, without prior notification, to the specification of incorporated components in line with its policy of continuous improvement and development.



www.uponor.com